



ENERSHIELD Air Barriers

Specializing in Energy Management Climate Control Systems

Energy Saving Technology

Manufacturing & Design

16813 – 113 Avenue, Edmonton Alberta T5M 2X2

Phone (780) 482-4662 • Fax (780) 482-4074

Toll Free – 1-866-464-3667

www.enershield.ca

Durashield DSH-192 - Air Barrier Specifications

Enershield model DSH-192 Enershield Air Barrier 192” (4877 mm) in length. Powder coated 1/8” steel frame construction & 20 gauge G.90 sheet metal jacket, c/w acoustic insulation with acrylic anti microbial coating. Air Barrier is provided with powder coated telescopic sliders & wall brackets, lockable remote NEMA 1 control panel incorporating soft start and photo electric cell door sensor for automatic activation upon door opening. Operating characteristics: 8 forward curved double inlet blowers providing Air Velocity = 5500 fpm, Air Volume = 25,800 cfm, Electrical: see chart below Motors: 2 @ 5 hp = 10 hp total (7460 Watts). Weight = 960 lbs. Decibel rating is 74 dB at a distance of 10’ from the unit. CSA Certified.

Warranty: 2 yrs parts.

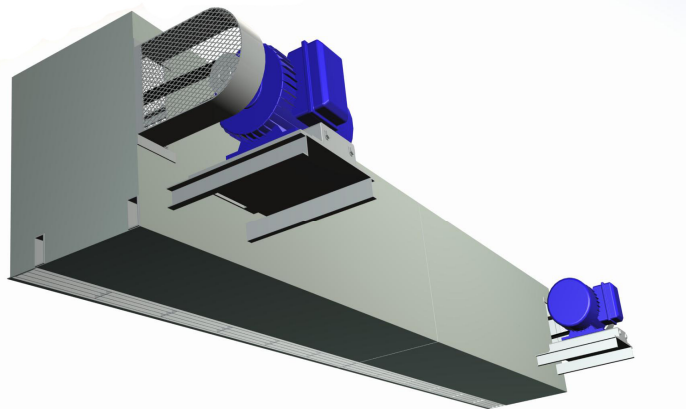

Model	DSH-192
Cabinet Length in./mm	192” 4877 mm
Height x Width	20”x 17 1/2” 508mm x 444mm
Weight lbs/Kgs	960 lbs. 436 kgs.
Horse Power	5 hp 3730 watts
Fans/Blowers	8
Motors TEFC	2
Total Horsepower	10 hp 7,460 watts
Decibels	74 dB
Max FPM at Nozzle	5500 fpm 27.9 m/s
CFM at Nozzle	25,800 cfm 12,176 l/s
Outlet Velocity Uniformity	95%

Available Motor(s)			
Operating Voltage:	575/3/60	460/3/60	208/3/60
Amp Draw FLA	5.2 Amps ea	6.5 Amps ea	14.4 Amps ea
TEFC Motor 1750 RPM, IP55, VFD Compatible, T-Frame, 89.5% Eff.			

nb: All units can be manufactured for a vertical application. Information available on request
4/17/2012